



FCC SDOC TEST REPORT

Equipment : 15.6" Healthcare Display
Model No. : TMD-25-15
Trade Name : TEGUAR
Applicant : Teguvar Co
Address : 2920 Whitehall Park Drive Charlotte,
NC 28273 United States
Standard : ANSI C63.4
FCC Part 18

HEREBY CERTIFY THAT :

The sample was received on : Jul. 07, 2021

The testing was carried out on : Aug. 13, 2021 ~ Aug. 17, 2021

The test result refers exclusively to the test presented test model / sample.
Without written approval of CerpPASS Technology Corp., the test report shall not be reproduced except in full.

Approved by:

Kero Kuo / EMC/RF Manager





Contents

Summary of Test Results	4
1. Applicable Standards	4
2. General Description	4
2.1. Product Details.....	4
2.2. Accessories.....	4
3. Test Configuration of Equipment under Test	5
3.1. Test Software.....	5
3.2. Test Manner.....	5
3.3. Description of Support Unit.....	6
3.4. General Information of Test.....	7
4. Test of Conducted Emission	8
4.1. Test Limit.....	8
4.2. Test Procedures.....	8
4.3. Typical Test Setup.....	9
4.4. Test Result and Data of Power Port.....	10
4.5. Test Photographs of Power Port.....	12
5. Test of Magnetic Field Radiated Emission	13
5.1. Test Limit.....	13
5.2. Test Procedures.....	14
5.3. Typical Test Setup.....	14
5.4. Test Result and Data.....	15
5.5. Test Photographs.....	17
6. Test of Radiated Emission	18
6.1. Test Limit.....	18
6.2. Test Procedures.....	19
6.3. Typical Test Setup.....	19
6.4. Test Result and Data (30MHz ~ 1GHz).....	21
6.5. Test Result and Data (1GHz ~ 18GHz).....	23
6.6. Test Result and Data (18GHz ~ 40GHz).....	25
6.7. Test Photographs (30MHz ~ 1GHz).....	27
6.8. Test Photographs (1GHz ~ 40GHz).....	28
7. Measurement Uncertainty	29
8. List of Measuring Equipment	29



History of this test report

Report No.	Issue Date	Description	Version
21070038-TEFV01	Apr. 08, 2022	Derivative Report	A

Report Type		Description
<input type="checkbox"/>	Original report	NA
<input checked="" type="checkbox"/>	Derivative Report	This sample provided has been confirmed to be identical to the original report sample. The only difference are as listed below. As it doesn't affect the test result, the original report number: 21060266-TEFV01 and content will be used. 1. Applicant information change. 2. Model No. change. 3. Trade Name change.



Summary of Test Results

1. Applicable Standards

The measurements shown in this test report were made in accordance with the procedures given in ANSI C63.4 – 2014 and the energy emitted by this equipment was passed Part 18.

Test Item	Normative References	Test Result
Conducted Emission	ANSI C63.4-2014 FCC Part 18	PASS
Radiated Emission	ANSI C63.4-2014 FCC Part 18	PASS

Note*: Pass criterion is defined by the applicant. The test report is to follow the applicant specification.

The lab has reduced the uncertainty risk factor from test equipment, environment and staff technicians which according to the standard on contract. Therefore, the test result will only be determined by standard requirement.

2. General Description

2.1. Product Details

Please refer to user manual.

2.2. Accessories

Item	Brand \ Model No.
Adapter	EDAC \ EM10681B
Panel	BOE \ PV156FHM-N20



3. Test Configuration of Equipment under Test

3.1. Test Software

An executive program, "BurnIn Test" under WIN 10, which generates a complete line of continuously repeating "H" pattern was used as the test software.

The program was executed as follows:

- a. Turn on the power of all equipment.
- b. The PC reads the test program from the hard disk drive and runs it.
- c. The PC sends "H" messages to the monitor, and the monitor displays "H" patterns on the screen.
- d. Repeat the steps from b to c.

At the same time, the following program was executed:

Executed "BurnIn Test" to play 1kHz audio.

3.2. Test Manner

- a. During testing, the interface cables and equipment positions were varied according to ANSI C63.4-2014.

- b. The test modes of EMI test as follow:

Conducted Emissions	
Test Mode 1	AC 120V, HDMI: 1920 x 1080 @60Hz
Test Mode 2	AC 120V, VGA: 1020 x 1080 @60Hz
Test Mode 3	AC 120V, HDMI: 1280 x 720 @60Hz
Test Mode 4	AC 240V, HDMI: 1920 x 1080 @60Hz
caused "Test Mode 1" generated the worst case, it was reported as the final data.	
Radiation Emissions	
Test Mode 1	AC 120V, HDMI: 1920 x 1080 @60Hz
Test Mode 2	AC 120V, VGA: 1020 x 1080 @60Hz
Test Mode 3	AC 120V, HDMI: 1280 x 720 @60Hz
Test Mode 4	AC 240V, HDMI: 1920 x 1080 @60Hz
caused "Test Mode 1" generated the worst case, it was reported as the final data.	

- c. The maximum operating frequency is above 108MHz, the test frequency range is from 30MHz to 18GHz.



3.3. Description of Support Unit

EMI				
No	Device	Manufacturer	Model No.	Description
For Local				
1	PC*2	DELL	XPS8700	Power Cable, Unshielding, 1.8m
2	Keyboard	DELL	KB216t	USB Cable, Shielding 1.85m
3	Mouse	DELL	MS1161	USB Cable, Shielding 1.85m
4	Printer	HP	P1102w	Power Cable, Unshielded 1.8m USB Cable, Shielding 1.6m
5	iPod	APPLE	A1320	USB Cable, Shielding 1.0m
Use Cable				
1	HDMI	N/A	N/A	Shielding 1.8m
2	VGA	N/A	N/A	Unshielding 1.8m
3	USB	N/A	N/A	Unshielding 1.8m
4	Audio	N/A	N/A	Unshielding, 1.8m



3.4. General Information of Test

Test Site	CerpPASS Technology Corporation Test Laboratory
	Address: No.10, Ln. 2, Lianfu St., Luzhu Dist., Taoyuan City 33848, Taiwan (R.O.C.) Tel:+886-3-3226-888 Fax:+886-3-3226-881
	<input checked="" type="checkbox"/> Conducted emission test (CON01-NK) <input type="checkbox"/> Conducted emission test (CON02-NK) <input checked="" type="checkbox"/> Radiated emission test (10M01-NK) <input checked="" type="checkbox"/> Radiated emission test (3M01-NK) <input type="checkbox"/> Radiated emission test (3M02-NK) <input checked="" type="checkbox"/> Radiated disturbance above 1GHz (10M01-NK) <input type="checkbox"/> Radiated disturbance above 1GHz (3M01-NK) <input type="checkbox"/> Radiated disturbance above 1GHz (3M02-NK)
	TW1079, TW1439
Frequency Range Investigated:	Conducted: from 150 kHz to 30 MHz Radiation: from 9 kHz to 40 GHz
Test Distance :	<p>The test distance of radiated emission 9KHz to 30MHz from antenna to EUT is 3 M.</p> <p>The test distance of radiated emission below 1GHz from antenna to EUT is 10 M.</p> <p>The test distance of radiated emission 1GHz ~ 18GHz from antenna to EUT is 3 M.</p> <p>The test distance of radiated emission 18GHz ~ 40GHz from antenna to EUT is 1M.</p>



4. Test of Conducted Emission

4.1. Test Limit

Conducted Emissions were measured from 150 kHz to 30 MHz with a bandwidth of 9 KHz, according to the methods defined in ANSI C63.4-2014. The EUT was placed on a nonmetallic stand in a shielded room 0.8 meters above the ground plane. The interface cables and equipment positioning were varied within limits of reasonable applications to determine the position produced maximum conducted emissions.

Table 1 Conducted Emission Limits (dB μ V):

Frequency range (MHz)	Quasi Peak	Average
0.15 to 0.50	66 to 56*	56 to 46*
0.50 to 5	56	46
5. to 30.	60	50

4.2. Test Procedures

- a. The EUT was placed 0.4 meter from the conducting wall of the shielding room was kept at least 80 centimeters from any other grounded conducting surface.
- b. Connect EUT to the power mains through a line impedance stabilization network (LISN).
- c. All the support units are connecting to the other LISN.
- d. The LISN provides 50 ohm coupling impedance for the measuring instrument.
- e. The FCC states that a 50 ohm, 50 micro-Henry LISN should be used.
- f. Both sides of AC line were checked for maximum conducted interference.
- g. The frequency range from 150 kHz to 30 MHz was searched.
- h. Set the test-receiver system to Peak Detect Function and Specified Bandwidth with Maximum Hold Mode.



4.3. Typical Test Setup

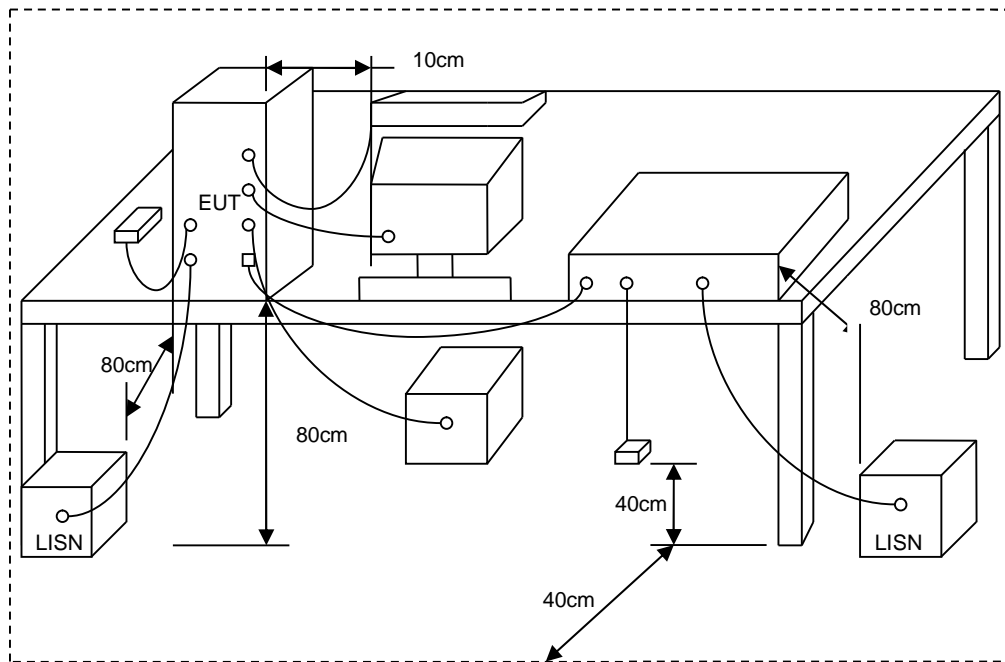



4.4. Test Result and Data of Power Port

Test Mode	Mode 1	Pol/Phase	LINE
Test Frequency	0.15 MHz ~ 30 MHz	Test Voltage	AC 120V
Test Date	Aug. 16, 2021	Test Engineer	Richard
Temperature	26°C	Relative Humidity	54%

Note : Level = Reading + Factor
 Margin = Level – Limit
 Factor= (LISN or PLC or Current Probe) Factor + Cable Loss + Attenuator

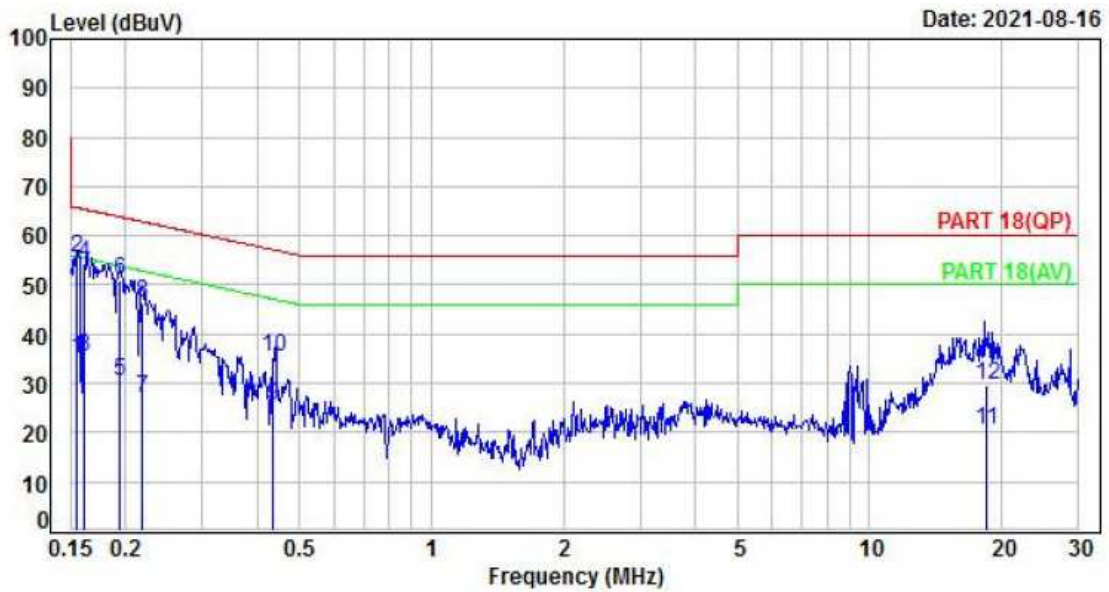

No.	Frequency (MHz)	Factor (dB)	Reading (dBuV)	Level (dBuV)	Limit (dBuV)	Margin (dB)	Detector	P/F
1	0.15	9.96	25.07	35.03	55.75	-20.72	Average	P
2	0.15	9.96	45.59	55.55	65.75	-10.20	QP	P
3	0.16	9.96	25.23	35.19	55.39	-20.20	Average	P
4	0.16	9.96	44.59	54.55	65.39	-10.84	QP	P
5	0.19	9.96	20.43	30.39	53.83	-23.44	Average	P
6	0.19	9.96	41.06	51.02	63.83	-12.81	QP	P
7	0.22	9.96	17.15	27.11	52.88	-25.77	Average	P
8	0.22	9.96	36.25	46.21	62.88	-16.67	QP	P
9	0.44	9.97	15.56	25.53	47.15	-21.62	Average	P
10	0.44	9.97	25.53	35.50	57.15	-21.65	QP	P
11	18.53	11.20	9.34	20.54	50.00	-29.46	Average	P
12	18.53	11.20	18.39	29.59	60.00	-30.41	QP	P



Test Mode	Mode 1	Pol/Phase	NEUTRAL
Test Frequency	0.15 MHz ~ 30 MHz	Test Voltage	AC 120V
Test Date	Aug. 16, 2021	Test Engineer	Richard
Temperature	26°C	Relative Humidity	54%

Note : Level = Reading + Factor
 Margin = Level – Limit
 Factor= (LISN or PLC or Current Probe) Factor + Cable Loss + Attenuator

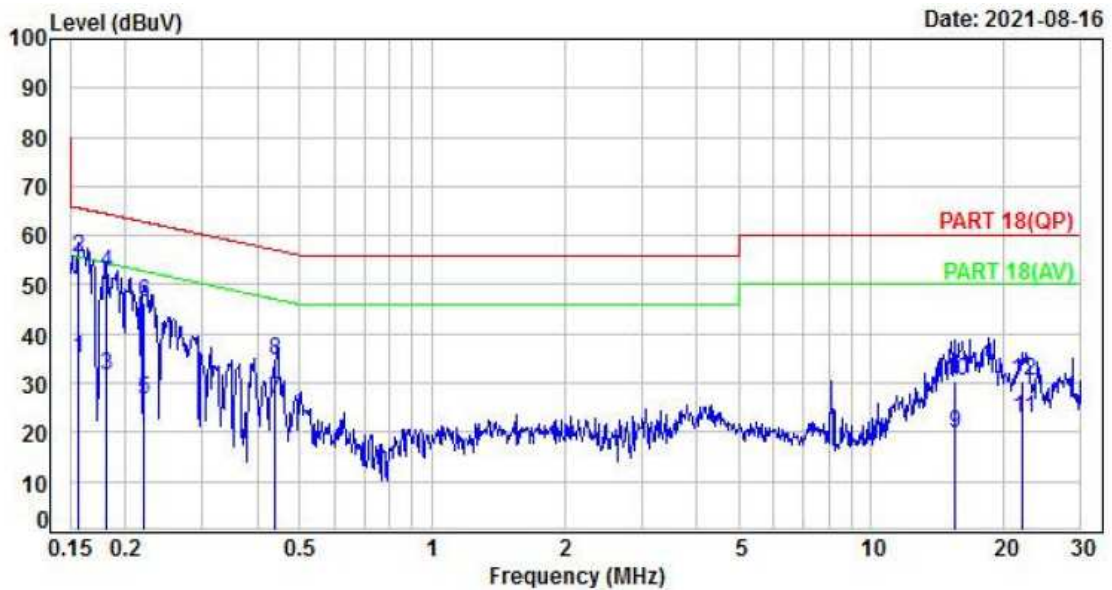

No.	Frequency (MHz)	Factor (dB)	Reading (dBuV)	Level (dBuV)	Limit (dBuV)	Margin (dB)	Detector	P/F
1	0.16	9.97	25.08	35.05	55.68	-20.63	Average	P
2	0.16	9.97	45.71	55.68	65.68	-10.00	QP	P
3	0.18	9.97	21.57	31.54	54.41	-22.87	Average	P
4	0.18	9.97	42.54	52.51	64.41	-11.90	QP	P
5	0.22	9.97	16.80	26.77	52.83	-26.06	Average	P
6	0.22	9.97	36.48	46.45	62.83	-16.38	QP	P
7	0.44	9.98	16.78	26.76	47.06	-20.30	Average	P
8	0.44	9.98	24.71	34.69	57.06	-22.37	QP	P
9	15.54	10.86	8.74	19.60	50.00	-30.40	Average	P
10	15.54	10.86	19.53	30.39	60.00	-29.61	QP	P
11	22.14	11.22	11.78	23.00	50.00	-27.00	Average	P
12	22.14	11.22	19.31	30.53	60.00	-29.47	QP	P



4.5. Test Photographs of Power Port

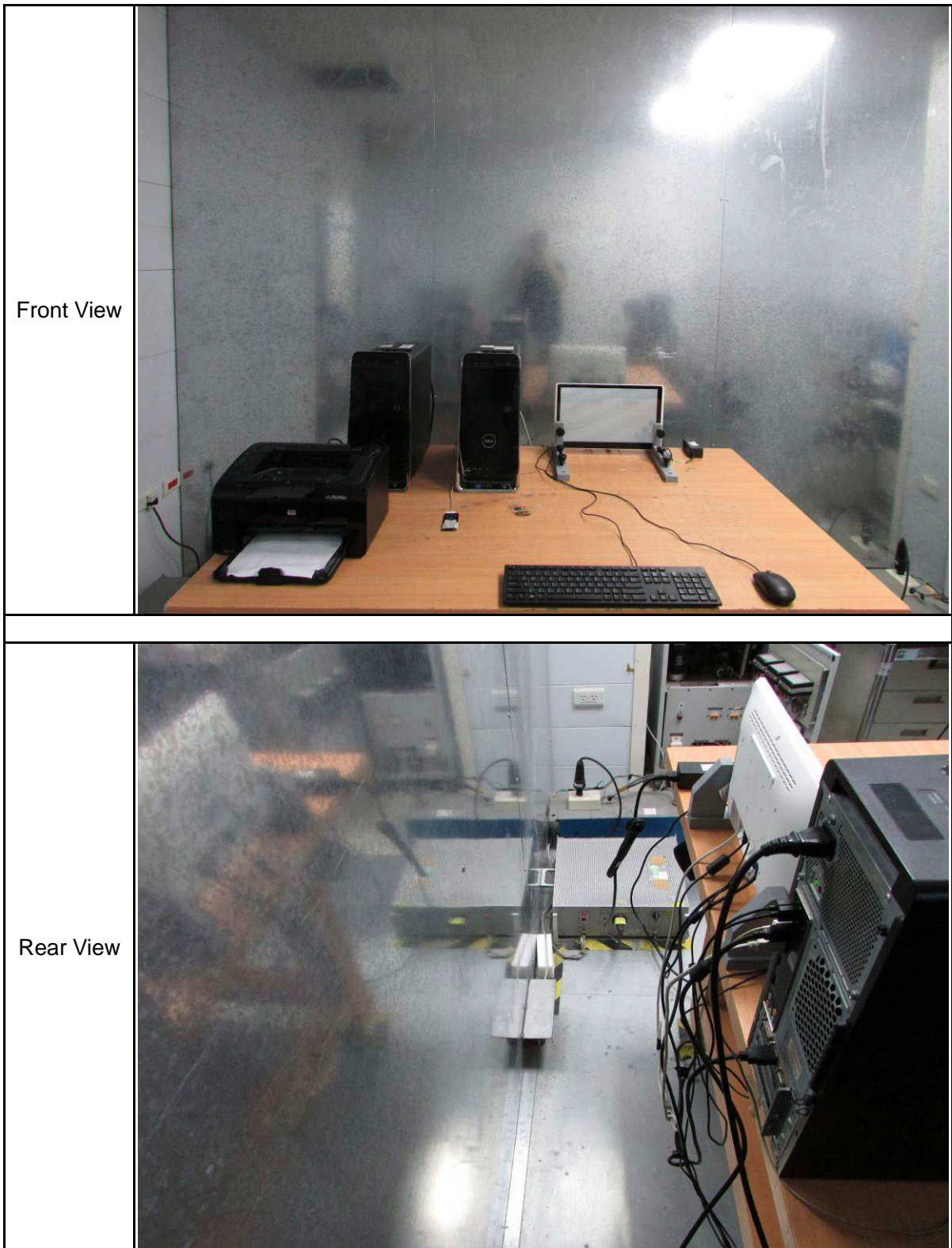



5. Test of Magnetic Field Radiated Emission

5.1. Test Limit

Magnetic field Radiated emissions from 9 KHz to 30 MHz were measured with a bandwidth of 120 kHz according to the methods defines in ANSI C63.4-2014. The EUT was placed on a nonmetallic stand in the open-field site, 0.8 meter above the ground plane. The interface cables and equipment positions were varied within limits of reasonable applications to determine the positions producing maximum Magnetic field radiated emissions.

Equipment	Operating frequency	RF Power generated by equipment (watts)	Field strength limit (uV/m)	Distance (meters)
Any type unless otherwise specified (miscellaneous)	Any ISM frequency	Below 500	25	300
		500 or more	$25 \times \text{SQRT}(\text{power}/500)$	$^1_{300}$
	Any non-ISM frequency	Below 500	15	300
		500 or more	$15 \times \text{SQRT}(\text{power}/500)$	$^1_{300}$
Industrial heaters and RF stabilized arc welders	On or below 5,725 MHz Above 5,725 MHz	Any Any	10 (²)	1,600 (²)
Medical diathermy	Any ISM frequency Any non-ISM frequency	Any	25	300
		Any	15	300
Ultrasonic	Below 490 kHz	Below 500	$2,400/F(\text{kHz})$	300
		500 or more	$2,400/F(\text{kHz}) \times \text{SQRT}(\text{power}/500)$	$^3_{300}$
	490 to 1,600 kHz	Any	24,000/F(kHz)	30
	Above 1,600 kHz	Any	15	30
Induction cooking ranges	Below 90 kHz On or above 90 kHz	Any	1,500	$^4_{30}$
		Any	300	$^4_{30}$

5.2. Test Procedures

- a. The object to be tested is placed on a rotatable wooden table 0.8 m away from the metal ground plane.
- b. Place the antenna 3m away from the object under test, and install the antenna on a horizontal and vertical antenna frame.
- c. Turn on the power of all supporting peripherals and equipment samples under test, and execute appropriate test procedures.
- d. Set the test instrument to the peak detection function and set the bandwidth and peak retention mode.
- e. The object to be tested is placed on the wooden table and rotated from 0 degrees to 360 degrees to obtain the angular position of the maximum radiated interference field strength.
- f. The antenna is moved from a height of 1 m above the ground with horizontal polarity and vertical polarity to obtain the maximum radiation intensity.
- g. If the radiation peak of the object under test is lower than the limit value by more than 6dB, the test will be terminated, and the peak value will be used as the report record; otherwise, if there is no radiation signal in the 6dB margin, each signal will be accurate The peak or average test method is measured and recorded in the report.

5.3. Typical Test Setup

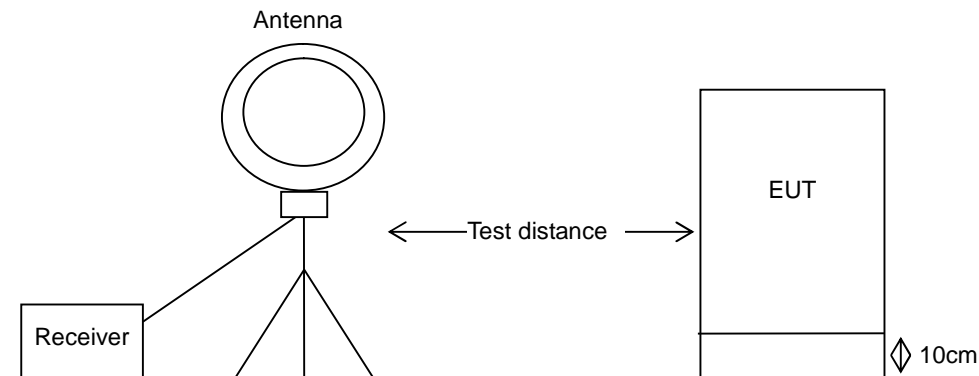



5.4. Test Result and Data

Test Mode	Mode 1	Pol/Phase	VERTICAL
Test Frequency	9 kHz ~ 30 MHz	Test Voltage	AC 120V
Test Date	Aug. 17, 2021	Test Engineer	Tien
Temperature	26.8°C	Relative Humidity	49%

Note : Level = Reading + Factor
 Margin = Level – Limit
 Factor = Antenna Factor + Cable Loss – Amplifier Factor

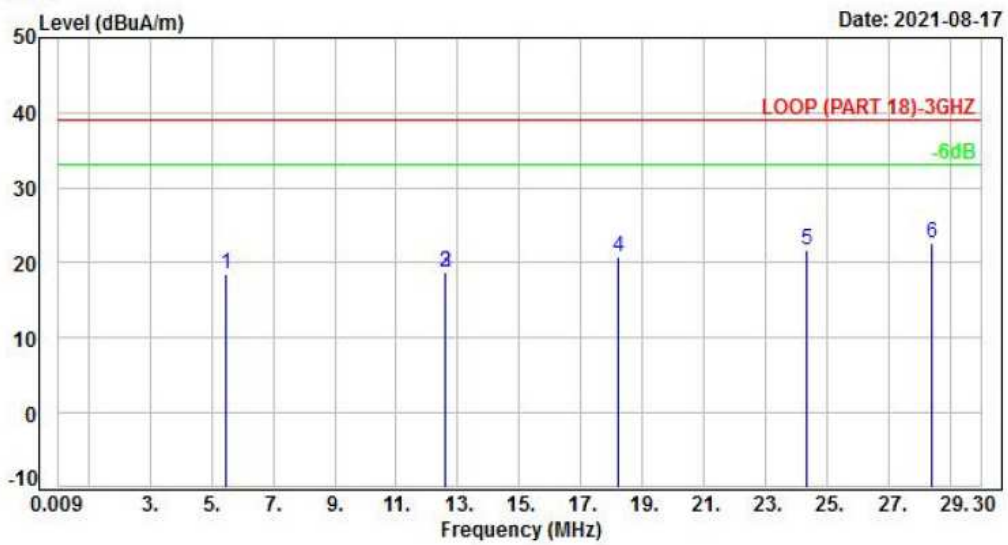

No.	Frequency (MHz)	Factor (dB/m)	Reading (dBuA)	Level (dBuA/m)	Limit (dBuA/m)	Margin (dB)	Detector	Height (cm)	Azimuth (deg)	P/F
1	5.47	16.61	1.94	18.55	39.02	-20.47	Peak	100	0	P
2	12.61	17.01	1.64	18.65	39.02	-20.37	Peak	100	0	P
3	12.61	17.01	1.64	18.65	39.02	-20.37	Peak	100	0	P
4	18.18	16.82	3.96	20.78	39.02	-18.24	Peak	100	0	P
5	24.33	16.35	5.35	21.70	39.02	-17.32	Peak	100	0	P
6	28.38	15.95	6.66	22.61	39.02	-16.41	Peak	100	0	P



Test Mode	Mode 1	Pol/Phase	HORIZONTAL
Test Frequency	9 kHz ~ 30 MHz	Test Voltage	AC 120V
Test Date	Aug. 17, 2021	Test Engineer	Tien
Temperature	26.8°C	Relative Humidity	49%

Note : Level = Reading + Factor
 Margin = Level – Limit
 Factor = Antenna Factor + Cable Loss – Amplifier Factor

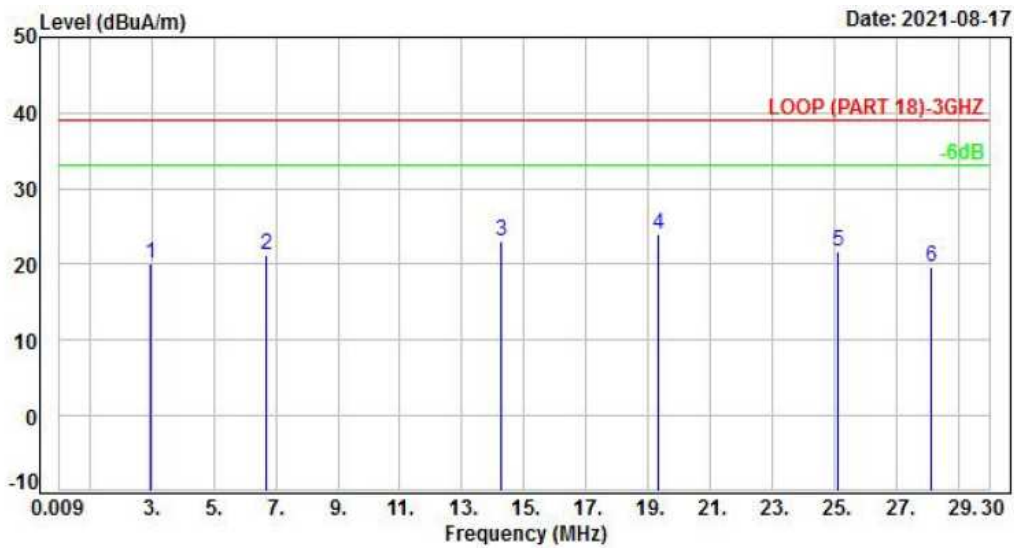

No.	Frequency (MHz)	Factor (dB/m)	Reading (dBUA)	Level (dBUA/m)	Limit (dBUA/m)	Margin (dB)	Detector	Height (cm)	Azimuth (deg)	P/F
1	2.98	16.23	3.98	20.21	39.02	-18.81	Peak	100	0	P
2	6.70	16.74	4.44	21.18	39.02	-17.84	Peak	100	0	P
3	14.25	16.95	6.22	23.17	39.02	-15.85	Peak	100	0	P
4	19.32	16.79	7.26	24.05	39.02	-14.97	Peak	100	0	P
5	25.08	16.27	5.55	21.82	39.02	-17.20	Peak	100	0	P
6	28.08	15.98	3.64	19.62	39.02	-19.40	Peak	100	0	P



5.5. Test Photographs

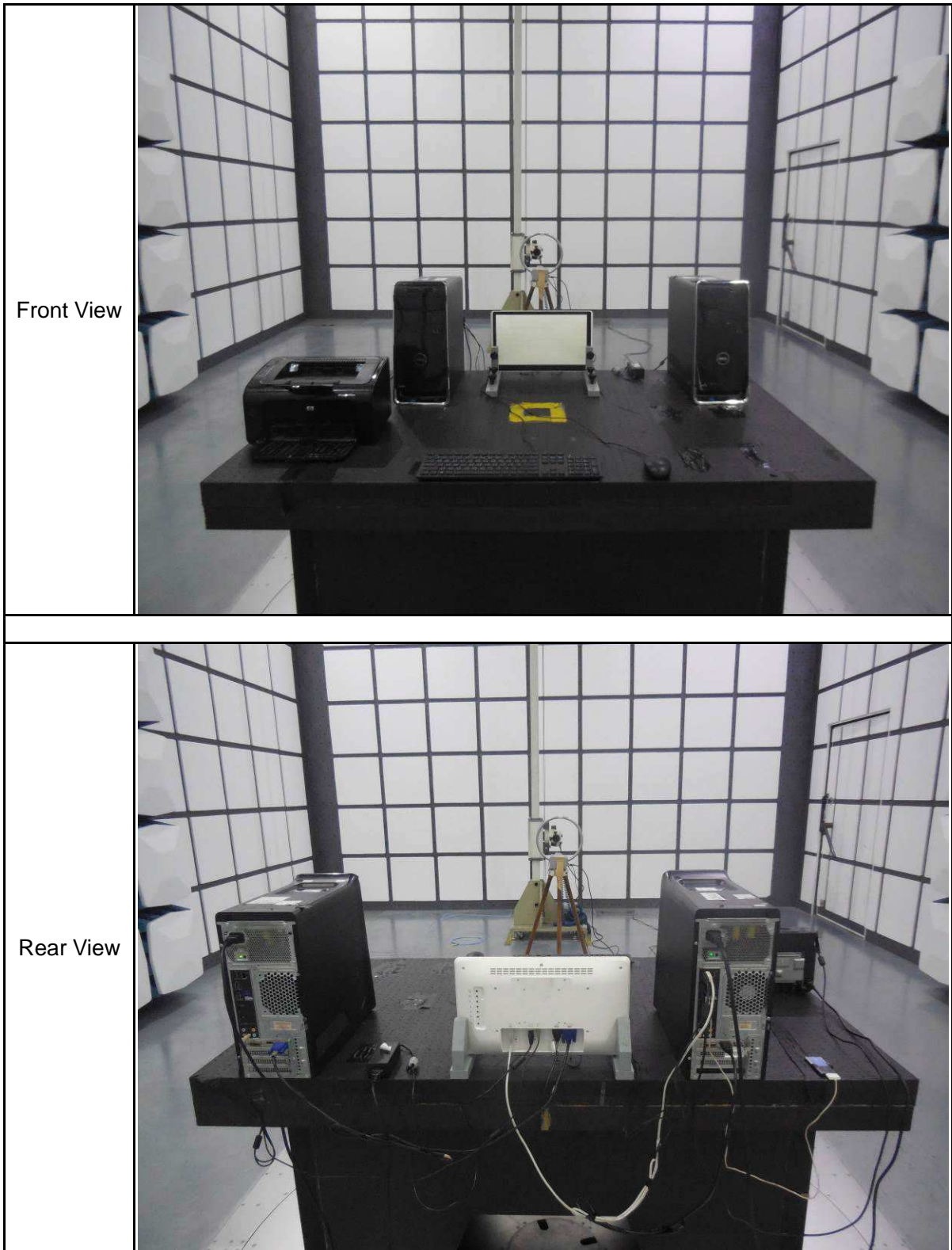



6. Test of Radiated Emission

6.1. Test Limit

Radiated emissions from 30 MHz to 40,000 MHz were measured with a bandwidth of 120 kHz according to the methods defines in ANSI C63.4-2014. The EUT was placed on a nonmetallic stand in the open-field site, 0.8 meter above the ground plane. The interface cables and equipment positions were varied within limits of reasonable applications to determine the positions producing maximum radiated emissions.

For unintentional device, according to § 15.109(a), except for Class A digital devices, the field strength of radiated emissions from unintentional radiators at a distance of 3 meters shall not exceed the following values:

Table 1 – Frequency below 1GHz

Frequency (MHz)	Distance Meters	Class A(dB μ V/m)	Class B(dB μ V/m)t
30-230	10	40	30
230-1000	10	47	37

Note: The limit for radiated test was performed according to CISPR 22, which was specified in FCC PART 15B 15.109(g).

Table 2 –Frequency above 1GHz

Frequency (GHz)	Distance Meters	Class A(dB μ V/m)		Class B(dB μ V/m)t	
		Peak	Average	Peak	Average
1-18	3	80.0	60.0	74.0	54.0
18-40	1	90.0	70.0	84.0	64.0

Note: (1) The lower limit shall apply at the transition frequencies.

(2) Emission level (dB μ V/m)= 20 log Emission level(μ V/m)

(3) All emission from a class A/B digital device or system, including any network of conductors and apparatus connected thereto, shall not exceed the level of field strengths specified above.

Table 3 –Frequency range of radiated measurement (for unintentional radiators)

Highest frequency generated or Upper frequency of measurement used in the device or on which the device operates or tunes(MHz)	Range(MHz)
Below 1.705	30
1.705-108	1000
108-500	2000
500-1000	5000
Above 1000	5th harmonic of the highest frequency or 40GHz, which is lower

6.2. Test Procedures

- a. The EUT was placed on a rotatable table top 0.8 meter above ground.
- b. The EUT was set 1/3/10 meters from the interference receiving antenna which was mounted on the top of a variable height antenna tower.
- c. The table was rotated 360 degrees to determine the position of the highest radiation.
- d. The antenna is a half wave dipole and its height is varied between one meter and four meters above ground to find the maximum value of the field strength both horizontal polarization and vertical polarization of the antenna are set to make the measurement.
- e. For each suspected emission the EUT was arranged to its worst case and then tune the antenna tower (from 1 M to 4 M) and turn table (from 0 degree to 360 degrees) to find the maximum reading.
- f. Set the test-receiver system to Peak Detect Function and specified bandwidth with Maximum Hold Mode.
- g. If the emission level of the EUT in peak mode was 6 dB lower than the limit specified, then testing will be stopped and peak values of EUT will be reported, otherwise, the emissions which do not have 6 dB margin will be repeated one by one using the quasi-peak method and reported.

6.3. Typical Test Setup

Below 1GHz Test Setup

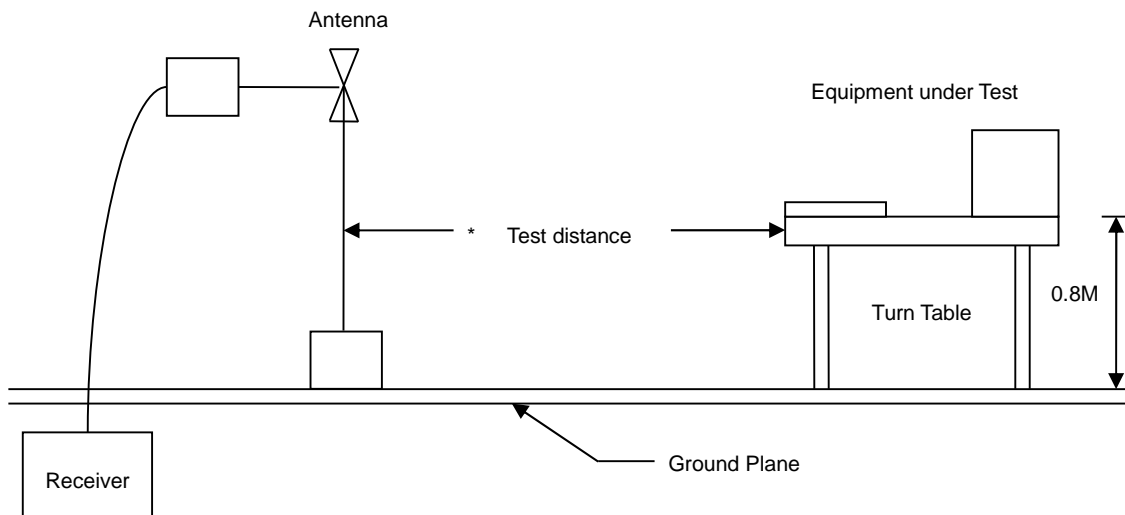



Above 1GHz Test Setup

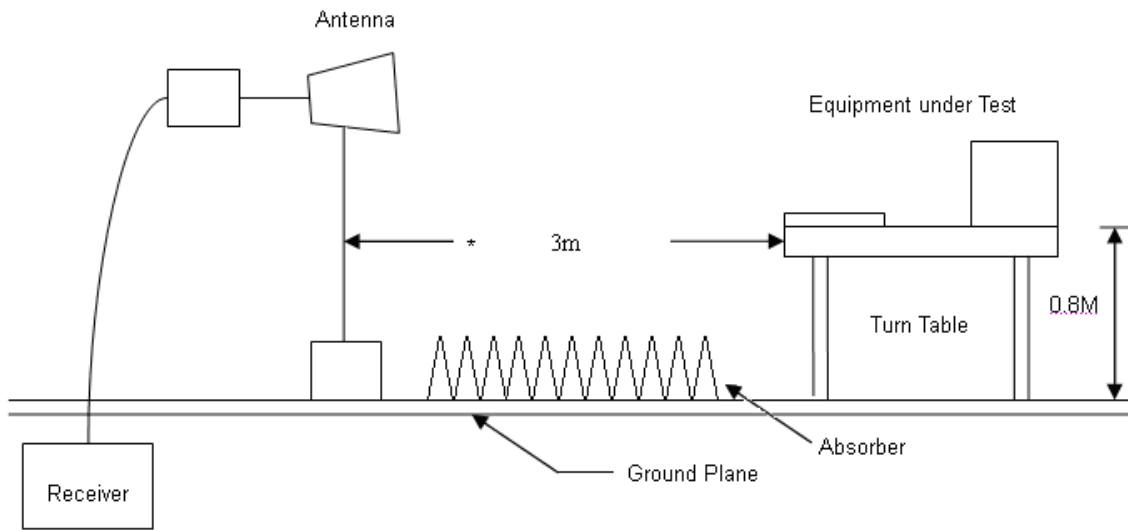



6.4. Test Result and Data (30MHz ~ 1GHz)

Test Mode	Mode 1	Pol/Phase	VERTICAL
Test Frequency	30 MHz ~ 1 GHz	Test Voltage	AC 120V
Test Date	Aug. 13, 2021	Test Engineer	Tien
Temperature	22 °C	Relative Humidity	55 %

Note : Level = Reading + Factor
 Margin = Level - Limit
 Factor = Antenna Factor + Cable Loss - Amplifier Factor

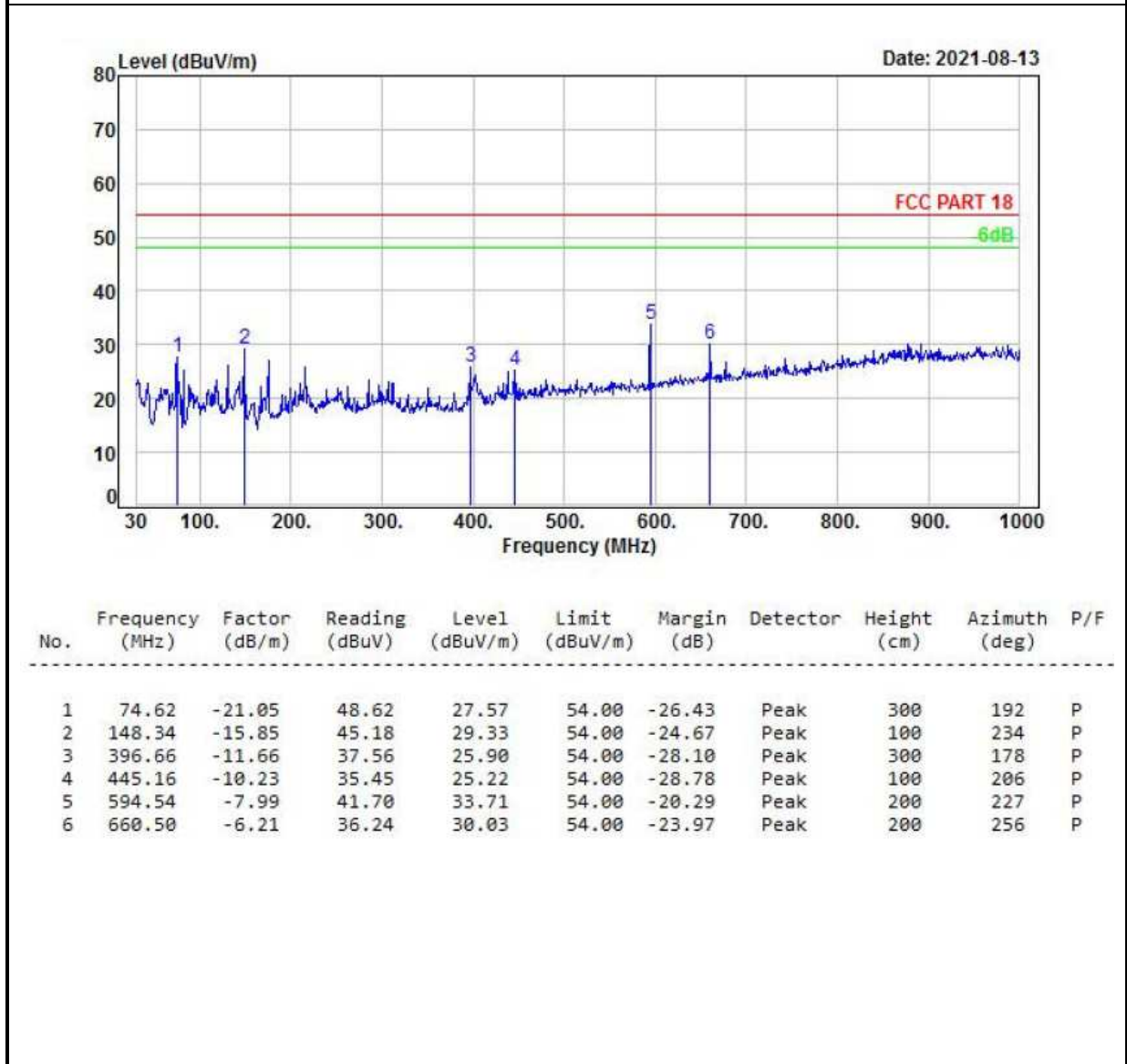



Test Mode	Mode 1	Pol/Phase	HORIZONTAL
Test Frequency	30 MHz ~ 1 GHz	Test Voltage	AC 120V
Test Date	Aug. 13, 2021	Test Engineer	Tien
Temperature	22 °C	Relative Humidity	55 %

Note : Level = Reading + Factor
 Margin = Level – Limit
 Factor = Antenna Factor + Cable Loss – Amplifier Factor

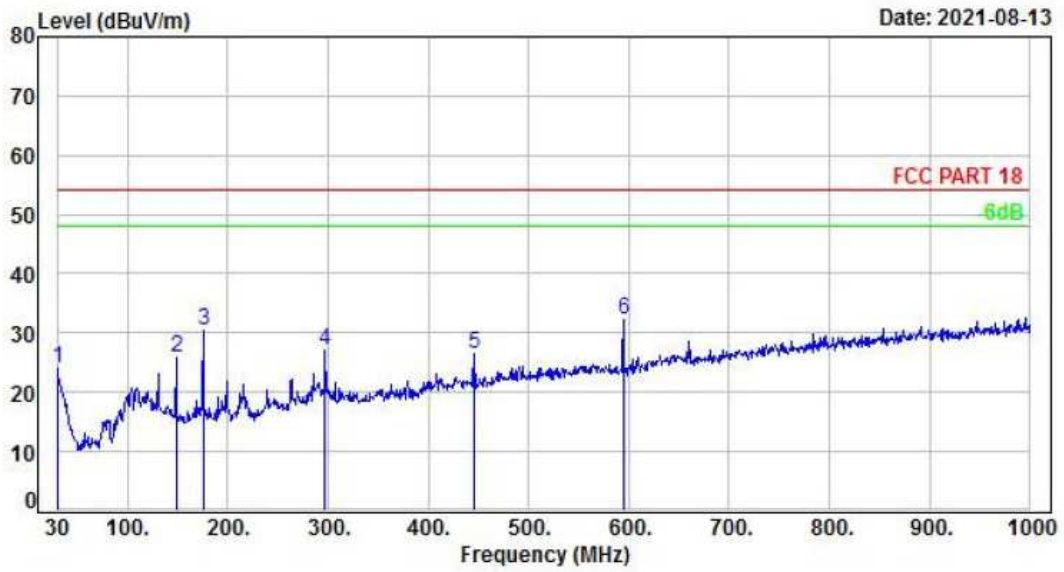

No.	Frequency (MHz)	Factor (dB/m)	Reading (dBuV)	Level (dBuV/m)	Limit (dBuV/m)	Margin (dB)	Detector	Height (cm)	Azimuth (deg)	P/F
1	30.00	-2.51	26.40	23.89	54.00	-30.11	Peak	100	173	P
2	148.34	-9.91	35.77	25.86	54.00	-28.14	Peak	300	235	P
3	175.50	-10.69	41.11	30.42	54.00	-23.58	Peak	400	80	P
4	296.75	-7.96	35.12	27.16	54.00	-26.84	Peak	300	291	P
5	445.16	-3.33	29.66	26.33	54.00	-27.67	Peak	200	129	P
6	594.54	-0.48	32.61	32.13	54.00	-21.87	Peak	200	261	P



6.5. Test Result and Data (1GHz ~ 18GHz)

Test Mode	Mode 1	Pol/Phase	VERTICAL
Test Frequency	1 GHz ~ 18 GHz	Test Voltage	AC 120V
Test Date	Aug. 13, 2021	Test Engineer	Tien
Temperature	22 °C	Relative Humidity	55 %

Note : Level = Reading + Factor
 Margin = Level – Limit
 Factor = Antenna Factor + Cable Loss – Amplifier Factor

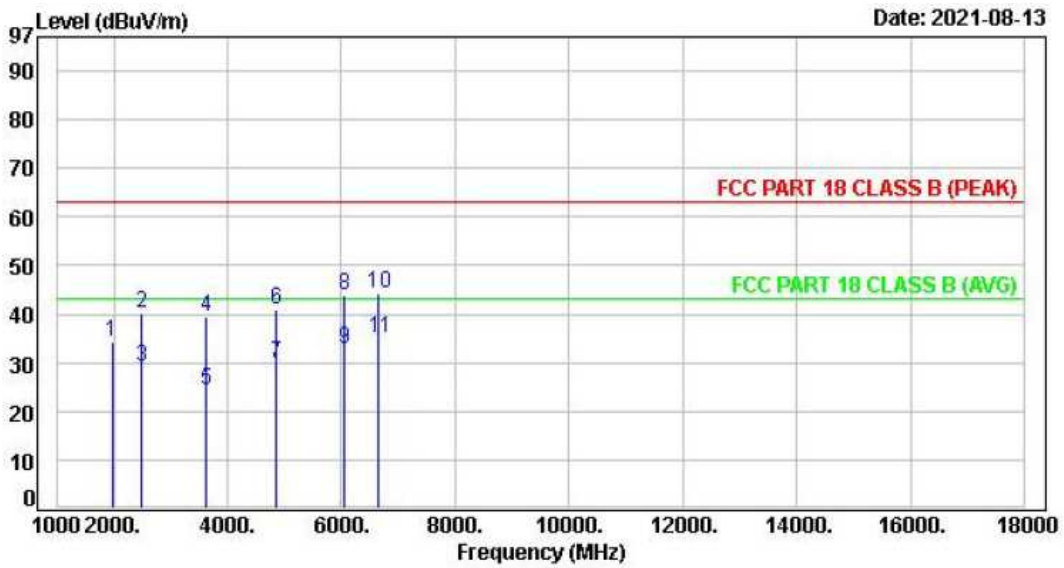

No.	Frequency (MHz)	Factor (dB/m)	Reading (dBuV)	Level (dBuV/m)	Limit (dBuV/m)	Margin (dB)	Detector	Height (cm)	Azimuth (deg)	P/F
1	1969.00	-15.75	50.22	34.47	63.00	-28.53	Peak	100	0	P
2	2479.00	-13.55	53.81	40.26	63.00	-22.74	Peak	100	255	P
3	2479.00	-13.55	42.81	29.26	43.00	-13.74	Average	100	255	P
4	3635.00	-10.27	49.70	39.43	63.00	-23.57	Peak	100	198	P
5	3635.00	-10.27	34.70	24.43	43.00	-18.57	Average	100	198	P
6	4859.00	-6.88	47.76	40.88	63.00	-22.12	Peak	100	255	P
7	4859.00	-6.88	36.76	29.88	43.00	-13.12	Average	100	255	P
8	6049.00	-4.41	48.27	43.86	63.00	-19.14	Peak	100	23	P
9	6049.00	-4.41	37.27	32.86	43.00	-10.14	Average	100	23	P
10	6661.00	-3.87	48.04	44.17	63.00	-18.83	Peak	100	320	P
11	6661.00	-3.87	39.04	35.17	43.00	-7.83	Average	100	320	P



Test Mode	Mode 1	Pol/Phase	HORIZONTAL
Test Frequency	1 GHz ~ 18 GHz	Test Voltage	AC 120V
Test Date	Aug. 13, 2021	Test Engineer	Tien
Temperature	22 °C	Relative Humidity	55 %

Note : Level = Reading + Factor
 Margin = Level – Limit
 Factor = Antenna Factor + Cable Loss – Amplifier Factor

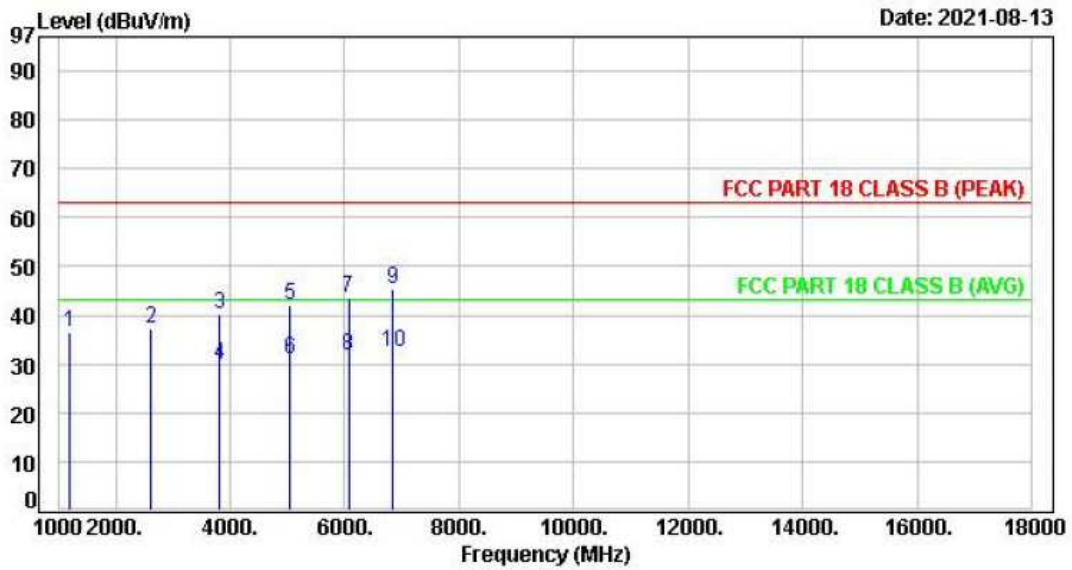

No.	Frequency (MHz)	Factor (dB/m)	Reading (dBuV)	Level (dBuV/m)	Limit (dBuV/m)	Margin (dB)	Detector	Height (cm)	Azimuth (deg)	P/F
1	1187.00	-17.42	53.91	36.49	63.00	-26.51	Peak	400	0	P
2	2615.00	-13.17	50.59	37.42	63.00	-25.58	Peak	400	0	P
3	3822.00	-9.70	49.74	40.04	63.00	-22.96	Peak	200	150	P
4	3822.00	-9.70	39.74	30.04	43.00	-12.96	Average	200	150	P
5	5029.00	-6.17	48.16	41.99	63.00	-21.01	Peak	200	194	P
6	5029.00	-6.17	37.16	30.99	43.00	-12.01	Average	200	194	P
7	6066.00	-4.52	48.14	43.62	63.00	-19.38	Peak	100	10	P
8	6066.00	-4.52	36.14	31.62	43.00	-11.38	Average	100	10	P
9	6831.00	-2.62	48.03	45.41	63.00	-17.59	Peak	200	150	P
10	6831.00	-2.62	35.03	32.41	43.00	-10.59	Average	200	150	P



6.6. Test Result and Data (18GHz ~ 40GHz)

Test Mode	Mode 1	Pol/Phase	VERTICAL
Test Frequency	18 GHz ~ 40 GHz	Test Voltage	AC 120V
Test Date	Aug. 17, 2021	Test Engineer	Tien
Temperature	25 °C	Relative Humidity	50 %

Note : Level = Reading + Factor
 Margin = Level – Limit
 Factor = Antenna Factor + Cable Loss – Amplifier Factor

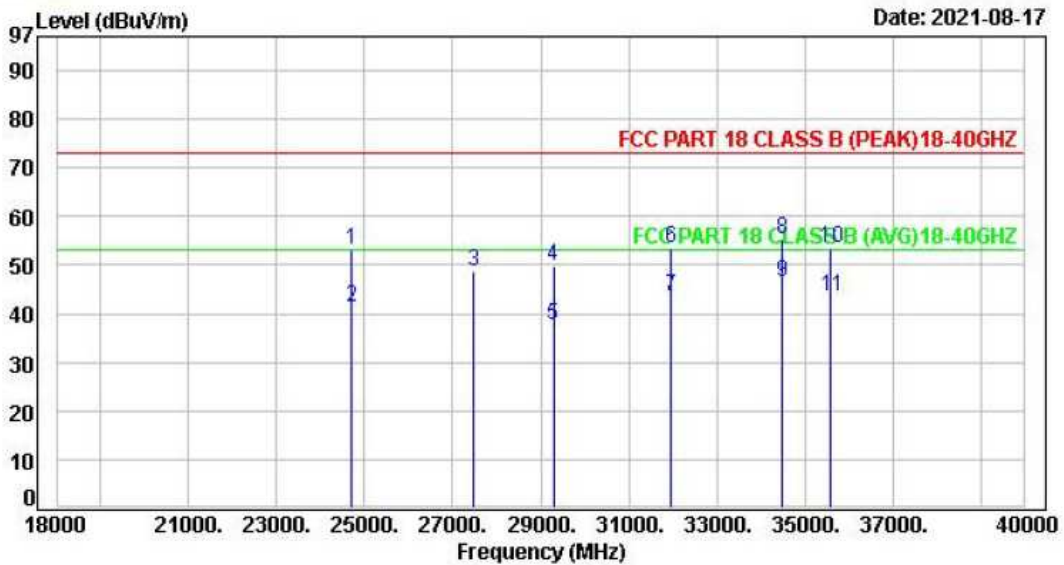

No.	Frequency (MHz)	Factor (dB/m)	Reading (dBuV)	Level (dBuV/m)	Limit (dBuV/m)	Margin (dB)	Detector	Height (cm)	Azimuth (deg)	P/F
1	24710.00	15.12	38.03	53.15	73.00	-19.85	Peak	200	150	P
2	24710.00	15.12	26.03	41.15	53.00	-11.85	Average	200	150	P
3	27460.00	15.66	32.85	48.51	73.00	-24.49	Peak	400	0	P
4	29286.00	16.47	33.31	49.78	73.00	-23.22	Peak	200	190	P
5	29286.00	16.47	21.31	37.78	53.00	-15.22	Average	200	190	P
6	31948.00	18.75	34.69	53.44	73.00	-19.56	Peak	200	100	P
7	31948.00	18.75	24.69	43.44	53.00	-9.56	Average	200	100	P
8	34500.00	23.66	31.71	55.37	73.00	-17.63	Peak	100	67	P
9	34500.00	23.66	22.71	46.37	53.00	-6.63	Average	100	67	P
10	35600.00	21.68	31.98	53.66	73.00	-19.34	Peak	100	119	P
11	35600.00	21.68	21.98	43.66	53.00	-9.34	Average	100	119	P



Test Mode	Mode 1	Pol/Phase	HORIZONTAL
Test Frequency	18 GHz ~ 40 GHz	Test Voltage	AC 120V
Test Date	Aug. 17, 2021	Test Engineer	Tien
Temperature	25 °C	Relative Humidity	50 %

Note : Level = Reading + Factor
Margin = Level – Limit
Factor = Antenna Factor + Cable Loss – Amplifier Factor

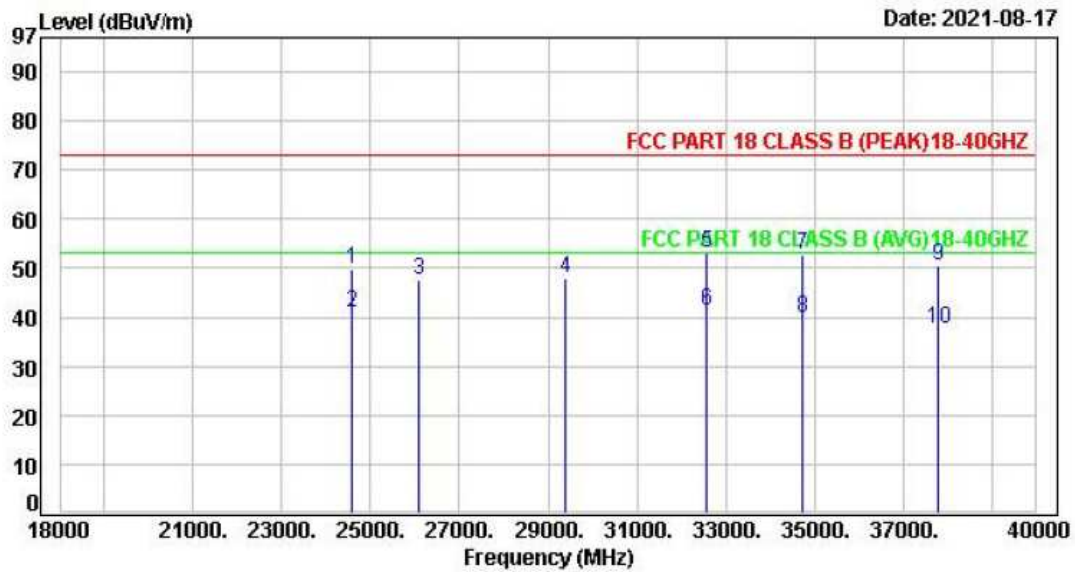

No.	Frequency (MHz)	Factor (dB/m)	Reading (dBuV)	Level (dBuV/m)	Limit (dBuV/m)	Margin (dB)	Detector	Height (cm)	Azimuth (deg)	P/F
1	24578.00	15.29	34.53	49.82	73.00	-23.18	Peak	300	50	P
2	24578.00	15.29	25.53	40.82	53.00	-12.18	Average	300	50	P
3	26074.00	15.50	32.20	47.70	73.00	-25.30	Peak	100	0	P
4	29374.00	16.61	31.20	47.81	73.00	-25.19	Peak	100	0	P
5	32564.00	19.79	33.45	53.24	73.00	-19.76	Peak	200	119	P
6	32564.00	19.79	21.45	41.24	53.00	-11.76	Average	200	119	P
7	34720.00	23.63	29.06	52.69	73.00	-20.31	Peak	300	159	P
8	34720.00	23.63	16.06	39.69	53.00	-13.31	Average	300	159	P
9	37778.00	18.69	31.98	50.67	73.00	-22.33	Peak	100	11	P
10	37778.00	18.69	18.98	37.67	53.00	-15.33	Average	100	11	P



6.7. Test Photographs (30MHz ~ 1GHz)

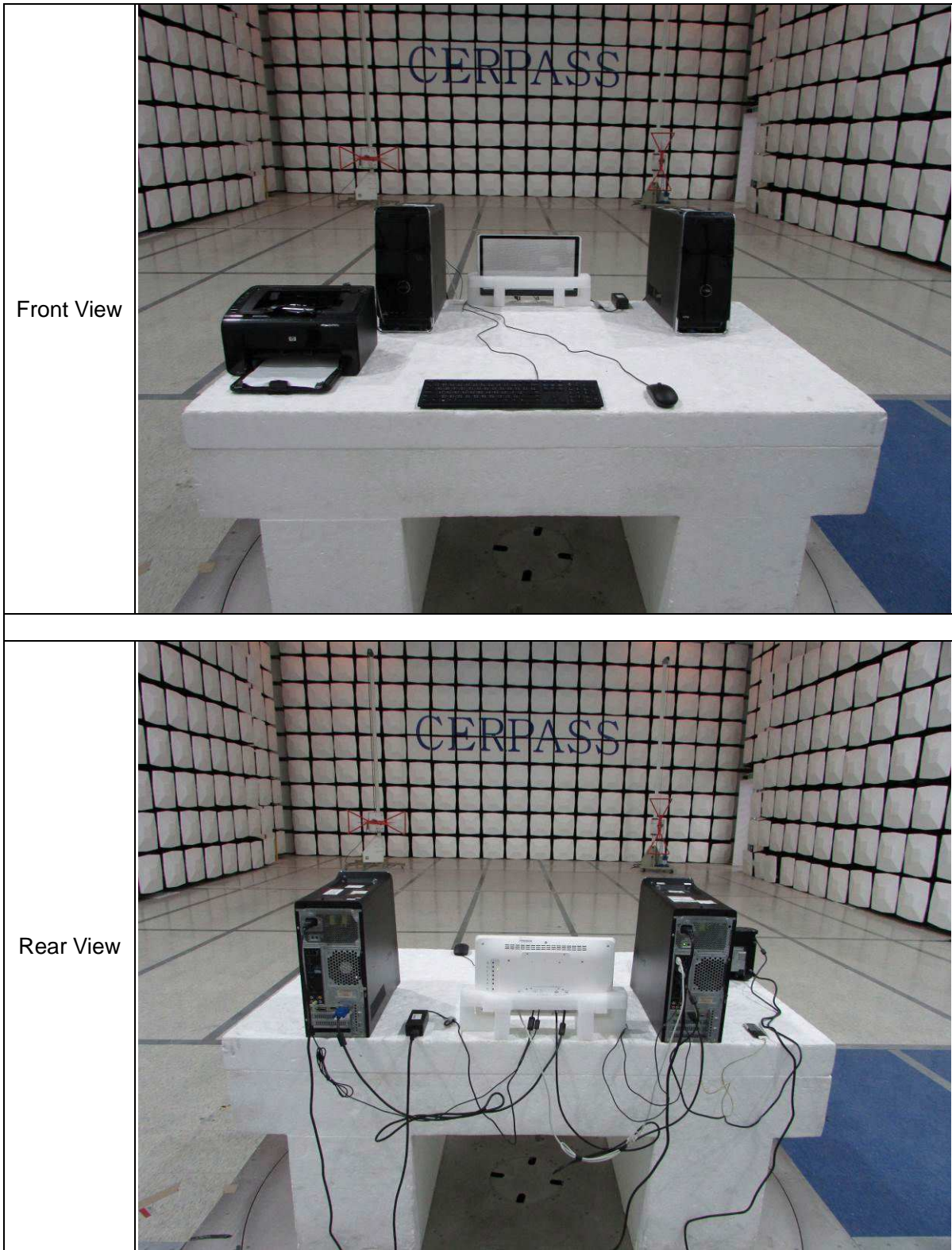



6.8. Test Photographs (1GHz ~ 40GHz)

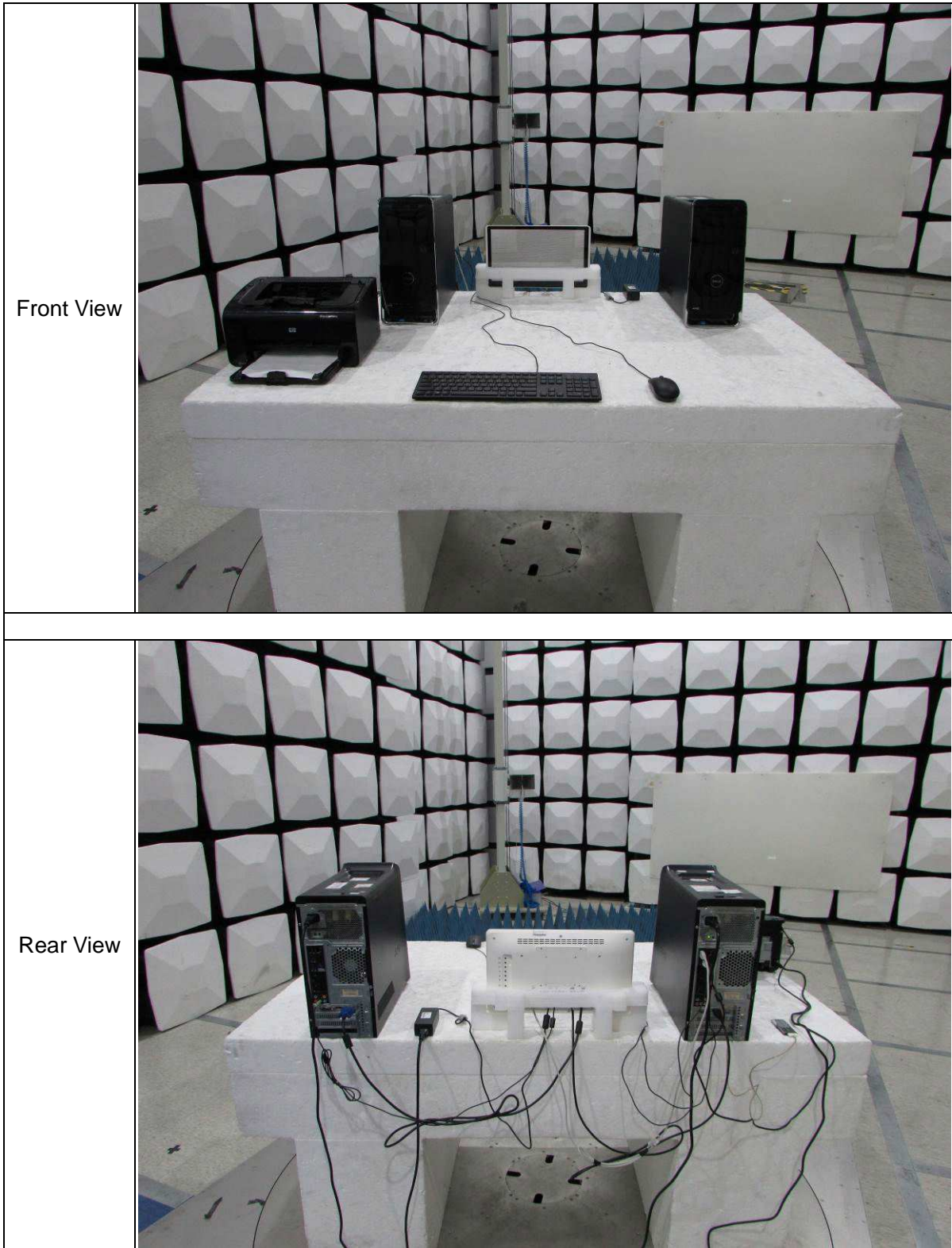



7. Measurement Uncertainty

Measurement Item	Measurement Frequency	Polarization	Uncertainty
Conducted Emission	150 kHz ~ 30 MHz	Line / Neutral	±3.63dB
Radiated Emission	30 MHz ~ 1,000 MHz	Vertical / Horizontal	±4.52dB
	1,000 MHz ~ 6,000 MHz	Vertical / Horizontal	±4.92dB
	6,000 MHz ~ 18,000 MHz	Vertical / Horizontal	±5.11dB

The measurement uncertainty will be considered, when test result margin to the limit.

8. List of Measuring Equipment

Conducted Emission (Test date: 2021/08/16)					
Instrument	Manufacturer	Model No.	Serial No.	Calibration Date	Valid Date
EMI Receiver	R&S	ESCI	100821	2020/09/11	2021/09/10
LISN	Schwarzbeck	NSLK 8127	8127-516	2020/09/26	2021/09/25
Pulse Limiter	R&S	ESH3-Z2	101933	2020/09/17	2021/09/16
Cable-6m (9kHz~300MHz)	N/A	EMC5D-BM-B M-6	130605	2020/09/18	2021/09/17
Software	AUDIX	E3	Version: V8.2014-8-6	N/A	N/A

Radiated Emission below 1GHz (Test date: 2021/08/13)					
Instrument	Manufacturer	Model No.	Serial No.	Calibration Date	Valid Date
Bilog Antenna(H)	Sunol	JB1	A020514-1	2021/03/18	2022/03/17
Bilog Antenna(V)	Sunol	JB1	A020514-2	2021/05/06	2022/05/05
EMI Receiver(V)	R&S	ESCI	100443	2021/05/20	2022/05/19
EMI Receiver(H)	R&S	ESCI	101402	2021/03/12	2022/03/11
Preamplifier(H)	EM Electronics corp.	EM330	60610	2021/03/09	2022/03/08
Preamplifier(V)	EM Electronics corp.	EM01M06G	60686	2020/10/20	2021/10/19
Cable-16m (30MHz-1GHz)(H)	HUBER SUHNER	RG-214	01110M	2021/03/26	2022/03/25
Cable-4m (30MHz-1GHz)(H)	HUBER SUHNER	RG-214	02951M	2021/03/26	2022/03/25
Cable-1m (30MHz-1GHz)(H)	HUBER SUHNER	RG-214	01098M	2021/03/26	2022/03/25
Cable-10m (30MHz-1GHz)(V)	HUBER SUHNER	RG-214	01126M	2021/04/22	2022/04/21
Cable-4m (30MHz-1GHz)(V)	HUBER SUHNER	RG-214	02953M	2021/04/22	2022/04/21
Cable-1m (30MHz-1GHz)(V)	HUBER SUHNER	RG-214	01099M	2021/04/22	2022/04/21
Software	AUDIX	E3	Version: V8.2014-8-6	N/A	N/A



Radiated Emission above 1GHz (Test date: 2021/08/13)					
Instrument	Manufacturer	Model No.	Serial No.	Calibration Date	Valid Date
Horn Antenna	Schwarzbeck	BBHA 9120 D	9120D-1785	2020/10/16	2021/10/15
Horn Antenna	EMCO	3116	31970	2021/03/29	2022/03/28
Spectrum Analyzer	R&S	FSV3044	101149	2021/06/04	2022/06/03
Preamplifier	EMC INSTRUMENTS	EMC184045	980065	2020/11/06	2021/11/05
Preamplifier	EM Electronics corp.	EM01G18G	60831	2021/06/25	2022/06/24
Cable-0.5m (30MHz-40GHz)	HUBER SUHNER	SUCOFLEX 102	36270/2	2021/03/10	2022/03/09
Cable-3m (1GHz-26.5GHz)	HUBER SUHNER	SUCOFLEX 102	28417/2	2021/03/10	2022/03/09
Cable-0.5m (1GHz-40GHz)	HUBER SUHNER	SF102	MY4569/2	2020/08/25	2021/08/24
Cable-6m (1GHz-40GHz)	HUBER SUHNER	SF102	MY5740/2	2020/08/25	2021/08/24
Software	AUDIX	E3	Version: V8.2014-8-6	N/A	N/A

Magnetic Field Radiated Emission (Test date: 2021/08/17)					
Instrument	Manufacturer	Model No.	Serial No.	Calibration Date	Valid Date
Active Loop Antenna	EMCO	6507	40855	2021/06/10	2022/06/09
Cable-6m (9kHz~300MHz)	N/A	EMC5D-BM-B M-6	130605	2020/09/18	2021/09/17
Software	AUDIX	E3	Version: V8.2014-8-6	N/A	N/A